

#66X Casing Bead

Expanded flange casing bead or Plaster Stop

Used as a stucco/plaster stop to provide a screed edge and protective finish trim while terminating plaster in a clear straight line at doors, windows, or other openings. Also, recommended as an edge divider between plaster and other dissimilar materials.

Product Data & Ordering Information:

Material: 26 Gauge, G-60 Hot-Dipped Galvanized Steel.
Also available in 99.97% pure Zinc, compliant with ASTM B-69.
Dimensions: 3/8" to 1-1/4" Grounds, 10' lengths.
Packaging: 20 Cartons per pallet.

09.22.36 (Metal Lath)

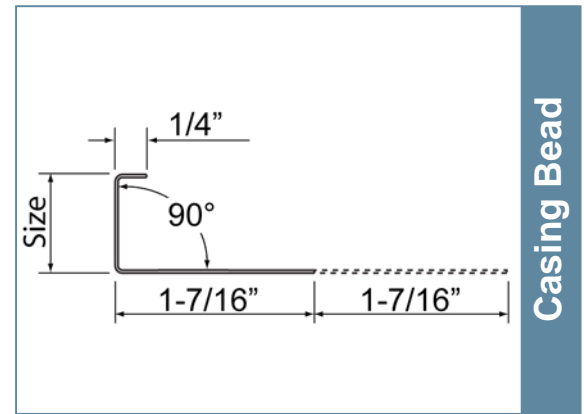

Size	Length	Pcs./Ctn.	Ft./Ctn.	Wt./Ctn.	Ctn/skid
3/8"	10'	30	300	46 lbs.	20
1/2"	10'	30	300	46 lbs.	20
5/8"	10'	30	300	49 lbs.	20
3/4"	10'	30	300	49 lbs.	20
7/8"	10'	30	300	54 lbs.	20
1"	10'	30	300	56 lbs.	20
1-1/4"	10'	30	300	60 lbs.	20

ASTM & Code Standards:

- ASTM C841 (interior), C1063 (exterior), CE 240.01, ASTM C926, ML/SFA-920, the International Code Council IBC and IRC.
- All Expanded Metal Lath Accessories are fabricated from prime galvanized steel G60 zinc coating by the hot dipped method, conforming to steel and coating specification ASTM A-653/A-653M or zinc alloy meeting ASTM B-69 as required in ASTM C1063 and C847.
- MSDS & Product Certification Information is available at www.clarkdietrich.com
- For installation and placement instructions refer to ASTM C1063, C841 and C926.

Storage:

All stored materials shall be kept dry. Materials shall be stacked off the ground, supported on a level platform, and protected from the weather and surface contamination conforming to ASTM C-1063

Limitations:

Galvanized steel products should not be used with magnesium oxychloride cement stucco or Portland cement stucco containing calcium chloride additives. The selection of the appropriate type of material for accessories shall be determined by the surrounding climatic and environmental conditions such as salt air, industrial pollution and high humidity.

GREEN Benefits and Recycled Content:

LEED Credit MR 2 - ClarkDietrich products are manufactured from cold-formed steel. Steel is 100% recyclable, which helps divert debris from the waste stream. The contribution to LEED must be calculated by the contractor based on weight or volume.

LEED Credit MR 4 - ClarkDietrich's steel products have a minimum recycled content of 34.9%, of which 24.3% is post-consumer, and 9.4% is pre-consumer. To report a higher number for your project or seek Credit MR 5, contact Technical Services at 888-437-3244 or visit www.clarkdietrich.com.

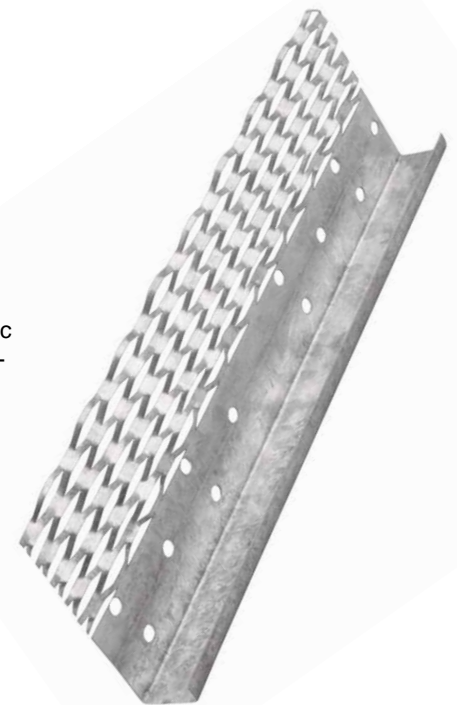

CD-Casing-#66X © 04/11 ClarkDietrich Building Systems

Project Information

Name:
Address:

Contractor Information

Name:
Contact:
Phone:
Fax:

Architect Information

Name:
Contact:
Phone:
Fax: